

Installation Guide

Flame Ionization Detector on a 6890 GC

Accessories G1561A, G1562A, G1591A, G1598A



Agilent Technologies

© Agilent Technologies 2001

All Rights Reserved. Reproduction, adaptation, or translation without permission is prohibited, except as allowed under the copyright laws.

Part number G1531-90327

First Edition, AUG 2001

Replaces Part No. G1531-90300, Installation Guide, Flame Ionization Detector, Part No. G1531-90305, Update for Flame Ionization Detector Accessory Installation Guide, and Part No. G1531-90320, Installing the Detector EPC Flow Control Manifold.

Printed in USA

Safety Information

The Agilent Technologies 6890 Gas Chromatograph meets the following IEC (International Electrotechnical Commission) classifications: Safety Class 1, Transient Overvoltage Category II, and Pollution Degree 2.

This unit has been designed and tested in accordance with recognized safety standards and designed for use indoors. If the instrument is used in a manner not specified by the manufacturer, the protection provided by the instrument may be impaired. Whenever the safety protection of the Agilent 6890 has been compromised, disconnect the unit from all power sources and secure the unit against unintended operation.

Refer servicing to qualified service personnel. Substituting parts or performing any unauthorized modification to the instrument may result in a safety hazard. Disconnect the AC power cord before removing covers. The customer should not attempt to replace the battery or fuses in this instrument. The battery contained in this instrument is recyclable.

Safety Symbols

Warnings in the manual or on the instrument must be observed during all phases of operation, service, and repair of this instrument. Failure to comply with these precautions violates safety standards of design and the intended use of the instrument. Agilent Technologies assumes no liability for the customer's failure to comply with these requirements.

WARNING

A warning calls attention to a condition or possible situation that could cause injury to the user.

CAUTION

A caution calls attention to a condition or possible situation that could damage or destroy the product or the user's work.



Indicates a hot surface



Indicates earth (ground) terminal

Sound Emission Certification for Federal Republic of Germany

Sound pressure $L_p < 68$ dB(A)

During normal operation
At the operator position
According to ISO 7779 (Type Test)

Schallemission

Schalldruckpegel $LP < 68$ dB(A)

Am Arbeitsplatz
Normaler Betrieb
Nach DIN 45635 T. 19 (Typprüfung)

Overview

This section reviews the procedure for installing a flame ionization detector (FID) on an Agilent 6890 Gas Chromatograph (hereafter referred to as the GC). Before following this procedure, refer to the safety information on the inside front cover.

Parts list

EPC

- FID assembly: capillary optimized or adaptable
- Top insulation
- Bottom insulation
- Nutwarmer cup and insulation (for adaptable FID only)

NonEPC

- FID assembly: capillary optimized or adaptable
- Top insulation
- Bottom insulation
- Makeup gas regulator
- Two machine screws
- Nutwarmer cup and insulation (for adaptable FID only)

Tools

- Electrostatic protection such as grounded wrist strap (part no 9300-0969 for large wrists or part no. 9300-0970 for small wrists)
- T-20 Torx screwdriver
- Diagonal cutters
- 7/16-inch wrench (nonEPC detectors only)

Overview

Steps

1. Preparing the GC
2. Installing the flow manifold
3. Installing the makeup gas regulator (nonEPC detectors only)
4. Positioning and securing the detector
5. Connecting the detector
6. Routing the tubing
7. Installing the nutwarmer cup (adaptable FID only)
8. FID chimney insert (optional)
9. Restoring the GC to operating condition
10. Calibrating your detector (EPC detector only)

Overview

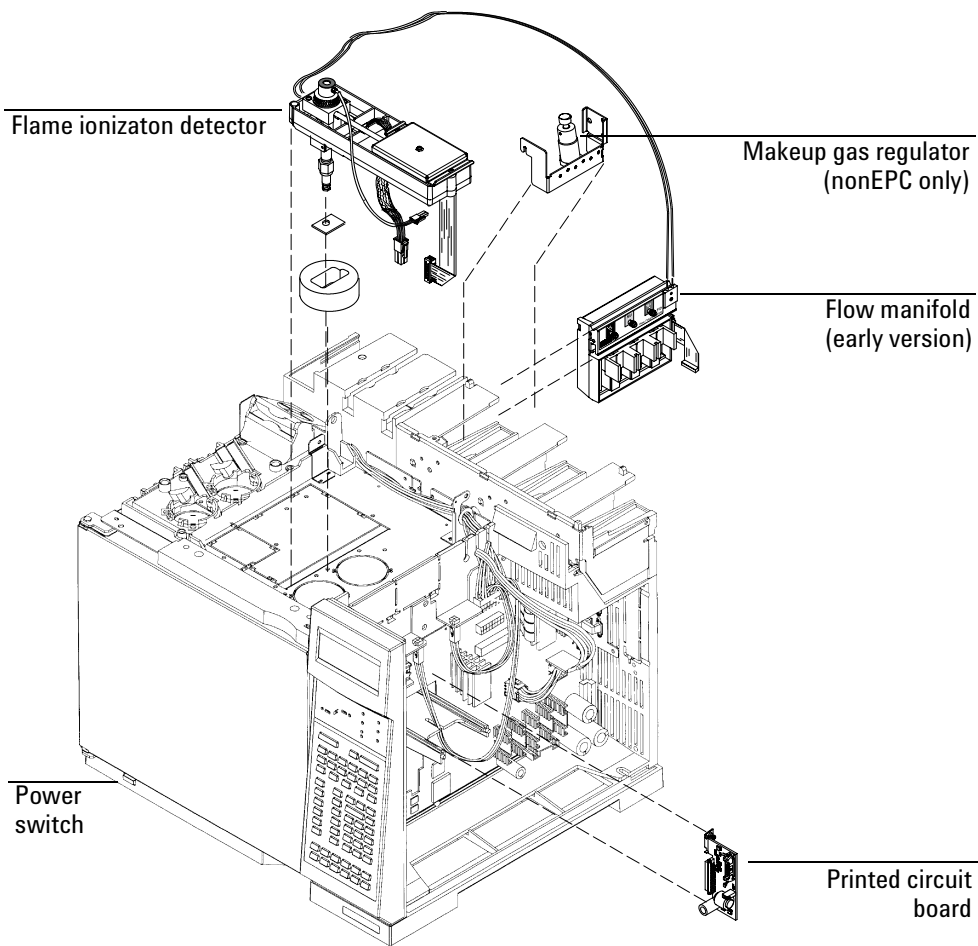

Preparing the GC

WARNING

Hazardous voltages are present in the mainframe when the GC is plugged in. Avoid a potentially dangerous shock hazard by unplugging the power cord before removing the side panels.

1. Turn off the GC and unplug the power cord. Allow time for all heated zones to cool and then turn off supply gases at their sources.

From the back of the GC (see figure on next page):

2. Unsnap and lift off the pneumatics top cover.
3. Remove the RFI cover. Remove the screw with a T-20 Torx screwdriver, slide the cover to the left until it disengages from the top rear panel, and remove it.
4. If you are installing a nonEPC detector, remove the detector cover plate from the front or back position by loosening the two screws with a T-20 Torx screwdriver and sliding the plate up and off.
5. Loosen the five screws in the top rear panel with a T-20 Torx screwdriver. Grasp the panel at each end and gently lift it up and then away from the GC. Be careful not to disrupt the supply tubing.

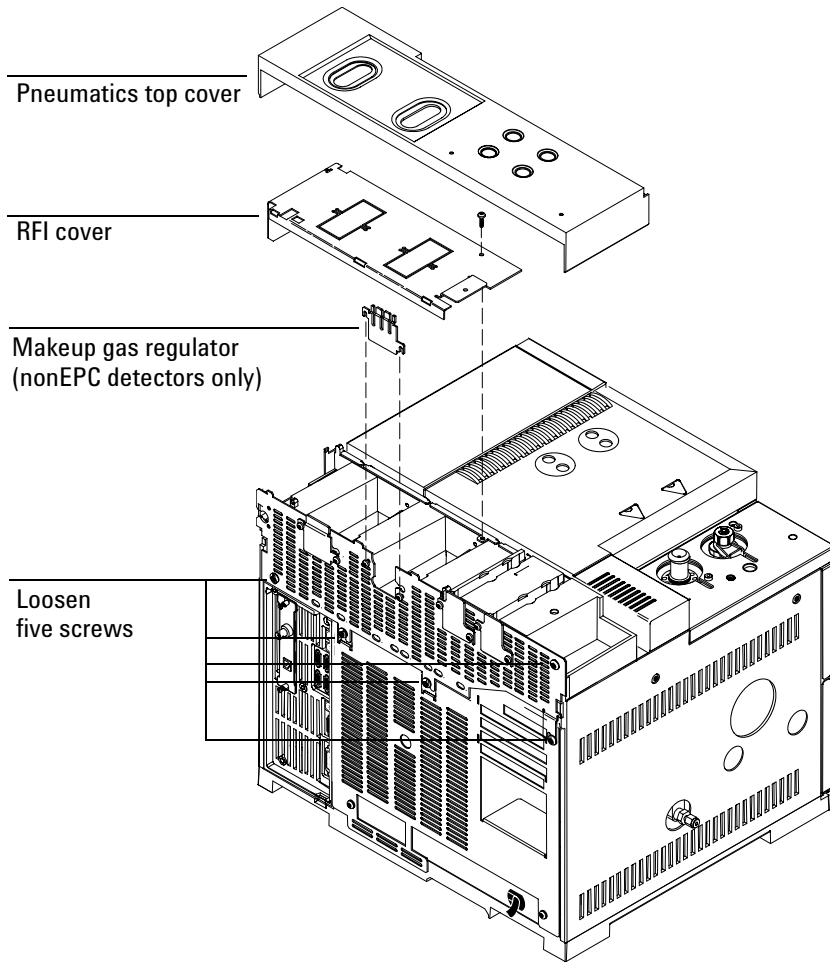

6. Raise the gray plastic top cover (with the holes and ventilation slots) to the vertical position. Examine the hinge in the right rear corner.
 - **Early 6890 models.** The hinge is a metal bracket attached to the oven top. Pull the clip at its top toward you to release the hinge pin. Push the pin to the left to release the cover. Tilt the cover to the left and remove it.
 - **Current 6890 models.** Tilt the cover to the left and remove it.

Preparing the GC

Caution

Board components can be damaged by static electricity; use a properly grounded static control wrist strap when removing the electronics covers.

7. Remove the electronics side cover. Loosen the two captive screws at the top, slide the panel to the rear, and lift it off.

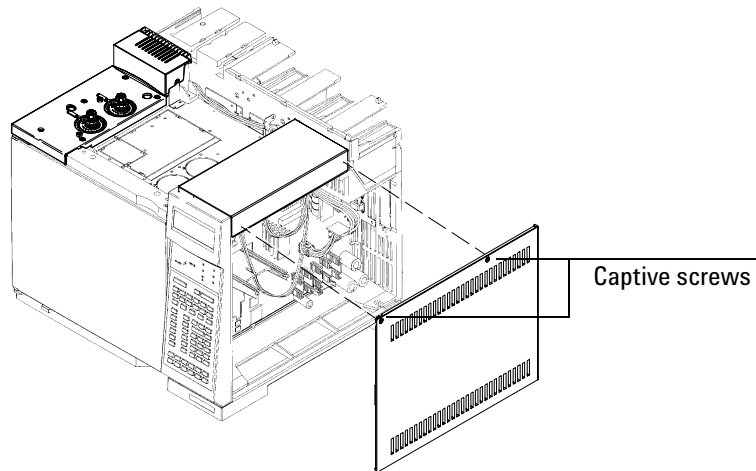

8. Remove the electronics top cover. Press the tab under the back end of the cover and lift it off.

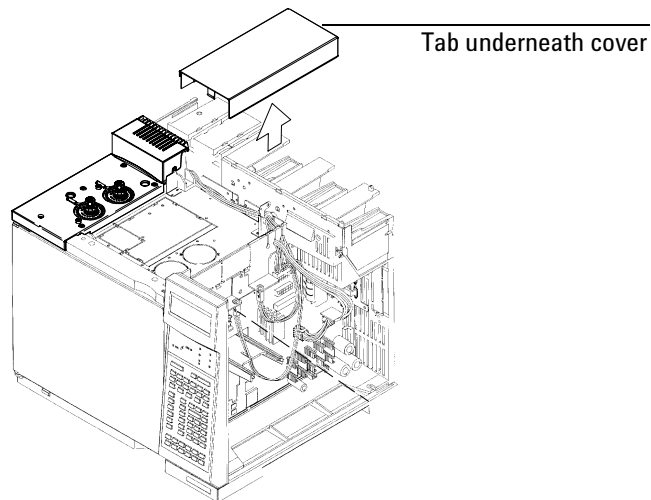

Installing the flow manifold

This section describes installation of the current version of the pneumatics module. For information on the earlier version, see the Appendix.

Caution

It is not necessary and not advisable to separate detectors from their pneumatics modules. Doing so can cause leaks. Although handling the detector and pneumatics module as a unit is awkward, it can be managed.

1. Locate the correct slot for the pneumatics module.
 - **Detector in the front position.** Use the second slot from the left (as viewed from the back of the GC).
 - **Detector in the back position.** Use the third slot from the left (as viewed from the back of the GC).

Caution

Hold the manifold by its support bracket to avoid damaging the components.

2. Route the ribbon cable behind the manifold assembly as shown in Figure 1. Then, slide the manifold and bracket assembly into the slot until the bracket seats flush against the end of the rails. See Figure 2.

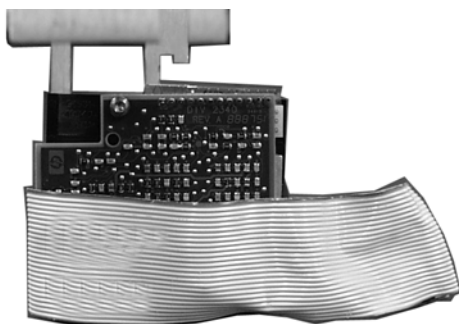

Back view of manifold

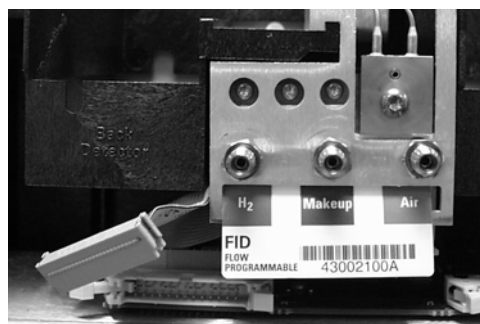

Manifold installed with cable routed to left

Figure 1. Routing the ribbon cable

Installing the flow manifold

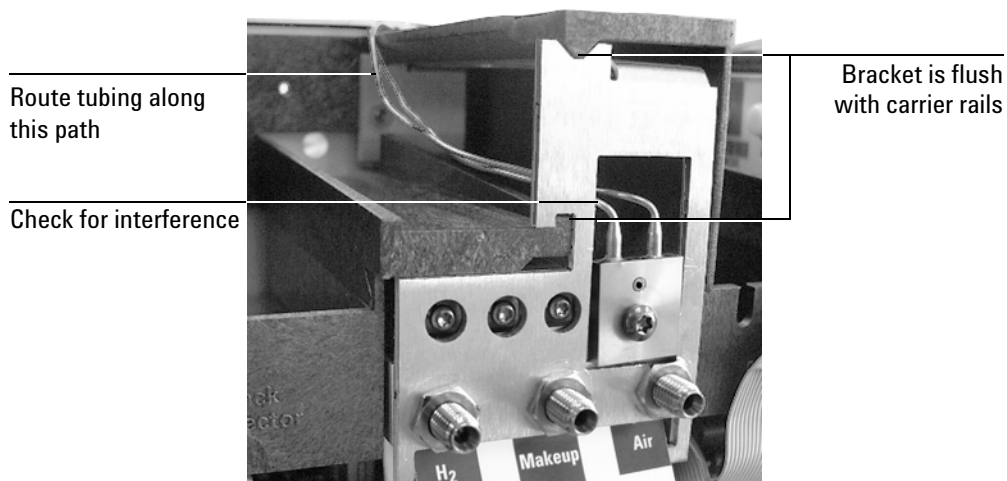

Figure 2. Manifold, after installation

3. Secure the manifold in place using a Torx T-20 screw from the front of the pneumatics chassis. See Figure 3.
4. Route the gas tubing over the top of the chassis and through the slots as shown in Figure 3.

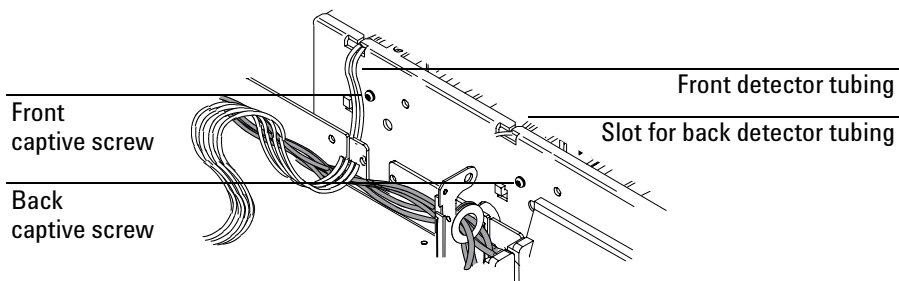

Figure 3. Captive screws and tubing

5. Connect the ribbon cable to the mating connector on the pneumatics board. Arrange the cable to keep it away from the valves and keep it from being pinched against the manifold.

For the back detector, you may want to loosen the manifold and slide it out of the carrier a few centimeters to connect the cable to the pneumatics board. Then, reinstall the manifold.

Caution

If your top rear panel is different from the one in Figure 4, discard it and use the one from the accessory kit.

- Using a pair of needle-nosed pliers, remove the appropriate top rear panel detector cutout for the FID. Also remove any cutouts needed to access other manifolds or accessories installed in the GC. See Figure 4.

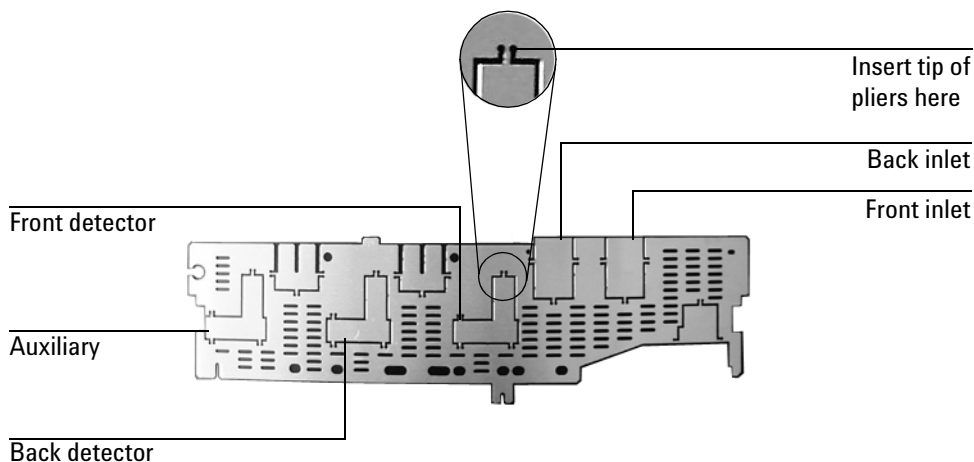

Figure 4. Top rear panel cutouts

- Install the RFI shield, the pneumatics cover, and the detector top cover.
- Connect the source gas lines to the manifold. See Figure 5.

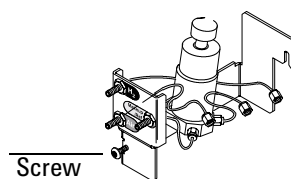
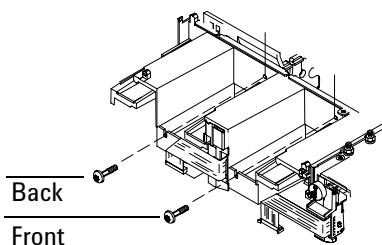

Figure 5. Gas line connections

Installing the makeup gas regulator (nonEPC detectors)

1. Install a screw in the front or back position of the pneumatics carrier. Do not tighten the screw.

Install a screw in the makeup gas regulator. Do not tighten the screw.



2. Place the makeup gas regulator in the front or back position of the pneumatics carrier. Tighten the screws with a T-20 Torx screwdriver.

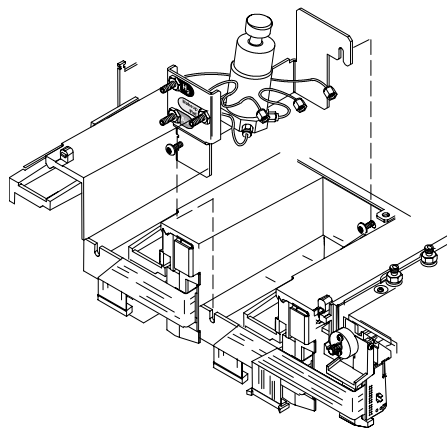

3. Connect the tube on the makeup gas regulator to the fitting labeled MU on the flow manifold. Tighten the nut fingertight, then use the 7/16-inch wrench to tighten it 3/4 of a turn. Follow the same procedure for

Installing the makeup gas regulator (nonEPC detectors)

connecting the air and hydrogen tubing (labeled at the back of the GC) to the flow manifold.

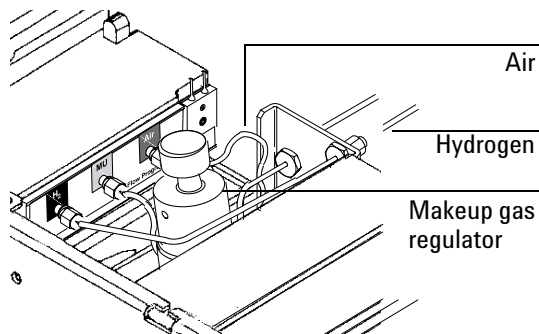

4. Locate the RFI cover that you removed in Preparing the GC. Remove the rectangular cutout in the front or back detector position. Use diagonal cutters to cut the metal in the two locations or work the cutout back and forth until it breaks free from the cover.

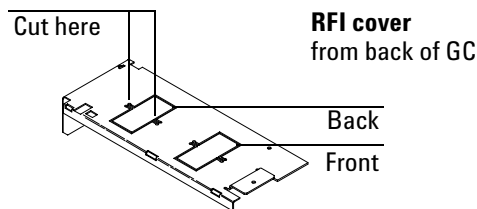

5. Locate the pneumatics cover that you removed in Preparing the GC. Remove the oval labels in the front or back detector position by pushing on the label from underneath the cover.

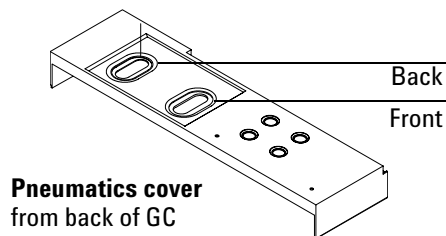

Positioning and securing the detector

1. Remove the round metal cutout on the oven top and the square plastic cutout in the electronics carrier in the front or back detector position, if necessary. Cut the metal circle with diagonal cutters so that the nibs are connected to the piece removed. Cut the plastic in six places with diagonal cutters. Discard the cutouts.

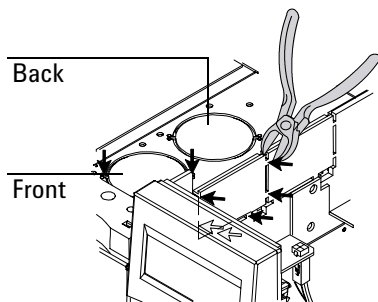

2. Lift out the die-cut insulation plug from the front or back detector position, if necessary.

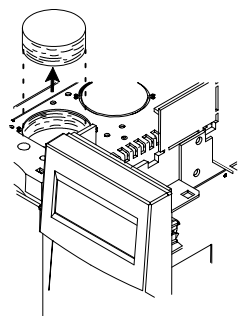

Caution

Be careful to remove only the insulation within the scribed circle.

3. Carefully remove the scribed circle of insulation from the oven top to create an opening into the oven.

Positioning and securing the detector

Method 1: Use a sharp knife to cut out the insulation using the scribed circle as a guide.

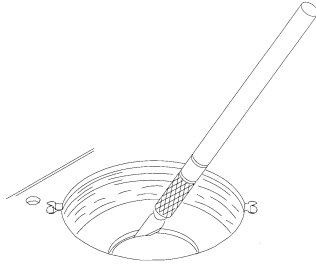

Method 2: Pierce the insulation with a screwdriver. Rotate the screwdriver around the edge of the scribed circle to remove excess insulation. Clean up any pieces of insulation that fall inside the oven.

4. Place the bottom insulation in the detector cavity.
5. Place the top insulation in the bottom insulation so that the hole in the insulation lines up with the hole in the oven top..
6. Place the detector pallet into the insulated cavity. Partially tighten the four screws with a T-20 Torx screwdriver. Tighten all the screws to snugness.

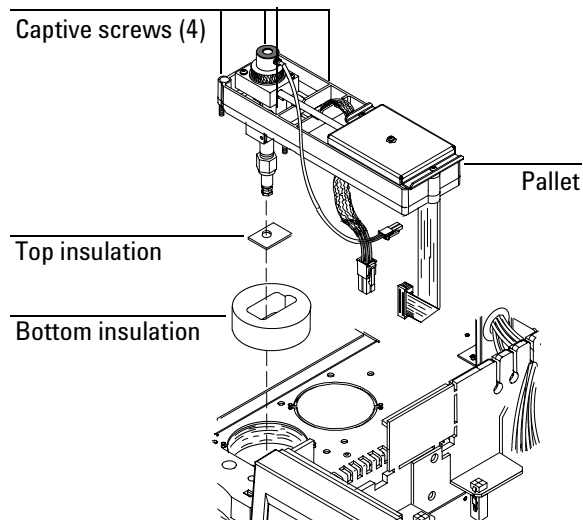

Connecting the detector

Caution

Board components can be damaged by static electricity; use a properly grounded static control wrist strap when handling the FID board.

1. Remove the PC board from its static control bag and slide into the front or back slot on the main circuit board until it is plugged in. Tighten the screw on the PC board bracket with a T-20 Torx screwdriver.

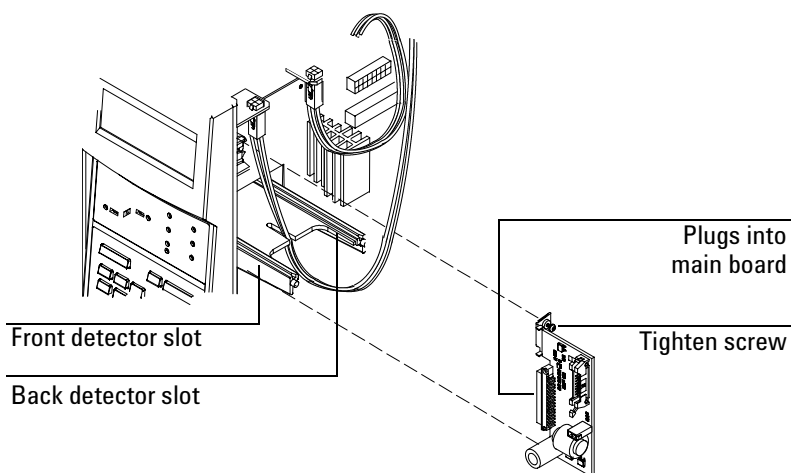

Connecting the detector

2. Attach the signal cable and ignition wire to the PC board, if not already connected.

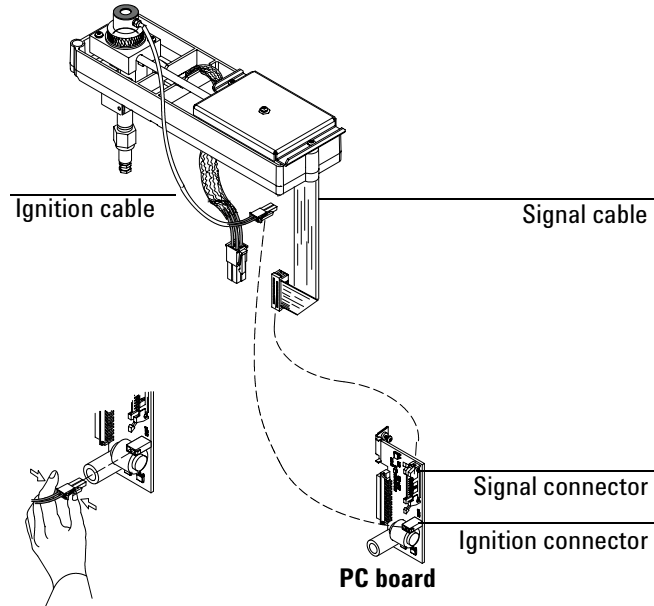

Connecting the detector

3. Connect the heater/sensor wire to the square connector closest to the front or back detector.

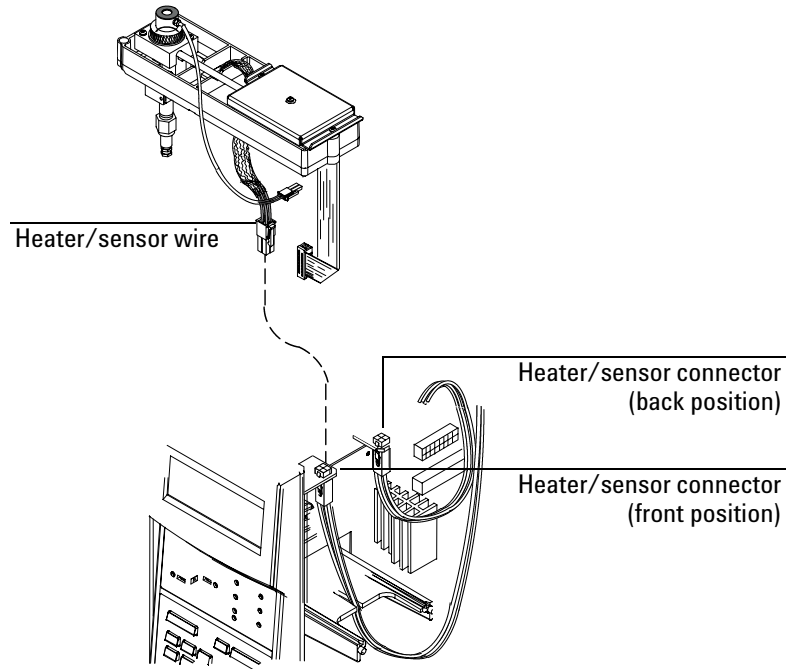

Routing the tubing

Route the tubing from the flow manifold over the top of the pneumatics chassis, through the appropriate slot, to the detector area.

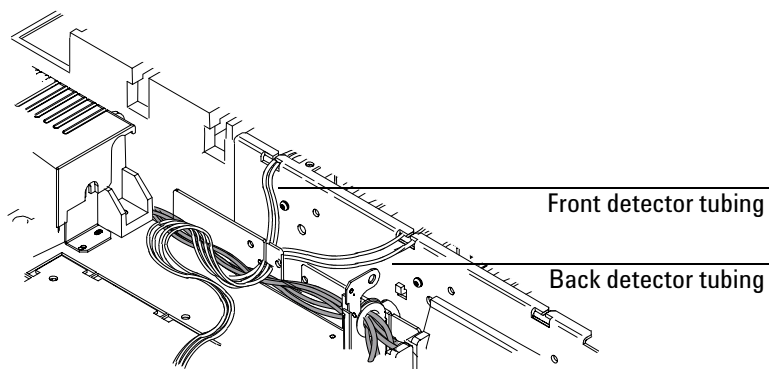

Installing the nutwarmer cup (adaptable FID)

1. Install the insulation in the cup.

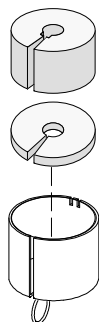

Installing the nutwarmer cup (adaptable FID)

2. Push the wire spring lever at the bottom of the cup to the right to uncover the hole.

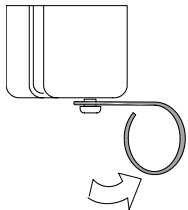

3. From inside the oven, place the cup over the detector fitting so that the top of the cup touches the top of the oven.

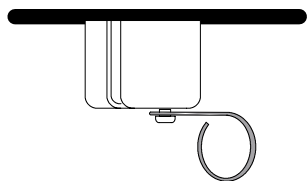

4. Release the spring. Make certain the spring fits in the groove of the detector fitting.

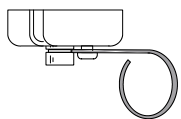

FID chimney insert (optional)

Install a PTFE chimney insert (part no. 19231-21050) if you are running highly corrosive analytes. These inserts may be ordered from the Agilent analytical supplies catalog.

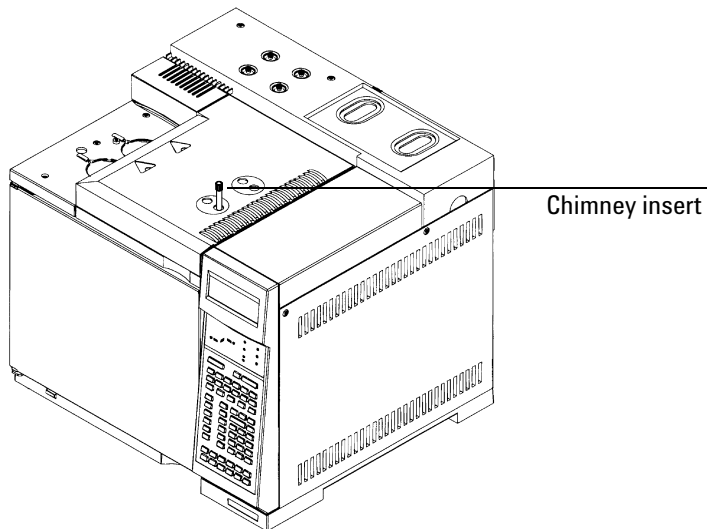

Restoring the GC to operating condition

1. Reinstall the electronics side panel.
2. Reinstall the top rear panel
3. Reinstall the detector cover.
4. Reinstall the electronics top cover.
5. Plug in the GC and turn it on.
6. Press [Front Det] or [Back Det]. If the detector has been properly installed, you will see the following display:

EPC

FRONT DET (FID)			
Temp	24	Off	<
H2 flow	0.x†	Off	
Air flow	0.x†	Off	
Mkup flow	0.x†	Off	
Flame		Off	
Output		0.0	

NonEPC

FRONT DET (FID)			
Temp	24	Off	<
H2 flow		Off	
Air flow		Off	
Mkup flow		Off	
Flame		Off	
Output		0.0	

† An actual flow value is displayed when the gases are off or not connected. This is not an error. After the gases are connected and the detector is operational, the actual flow values will be equal to the setpoint values.

Calibrating your detector (EPC only)

Your detector's flow manifold contains a pressure sensor that must be zeroed after it is installed on your GC. This calibration procedure ensures an accurate detector display.

Caution

Do not connect the detector and makeup gases to your flow manifold until you have zeroed your detector's pressure sensor.

1. Plug in your GC and turn it on, if you haven't already done so.
2. Wait 15 minutes. This allows your GC to reach thermal equilibrium.
3. Zero the detector's pressure sensor:
 - a. Press [Options], scroll to Calibration and press [Enter].
 - b. Scroll to Front detector or Back detector and press [Enter].
 - c. Scroll to Oxidizer zero and press [On].
 - d. Scroll to H2 zero and press [On].
 - e. Scroll to Makeup zero and press [On].
4. Turn off your GC and unplug the power cord.
5. Plumb the air, hydrogen, and makeup gases to your detector. See the *Agilent 6890 Site Preparation and Installation Manual* for instructions.
6. Reinstall the RFI cover.
7. Replace the pneumatics top cover.
8. Plug in the GC again and turn it on.

Appendix: Installing the pneumatics module (early version)

Caution

Board components can be damaged by static electricity; use a properly grounded static control wrist strap when removing the electronics covers.

1. From the back of the GC, locate the pneumatics carrier.

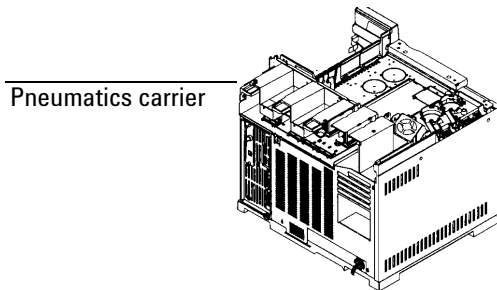

2. If you are installing a detector in the front position and an inlet is installed in the back position, unplug the back inlet ribbon cable. Unlock the connector by pushing the tabs away from the center.

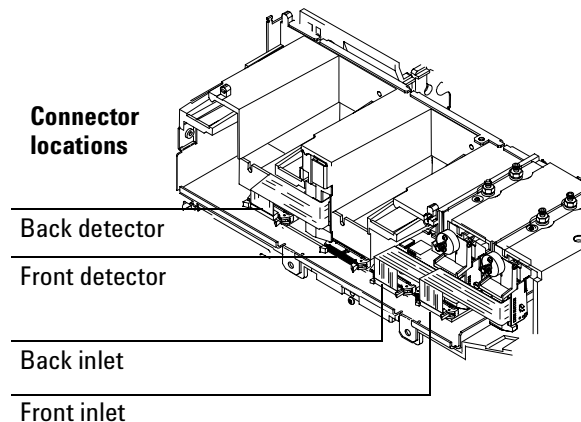

Appendix: Installing the pneumatics module (early version)

3. Locate the troughs in the flow manifold and the ridges in the pneumatics carrier. Slide the flow manifold into the carrier, lining up the ridges and troughs.

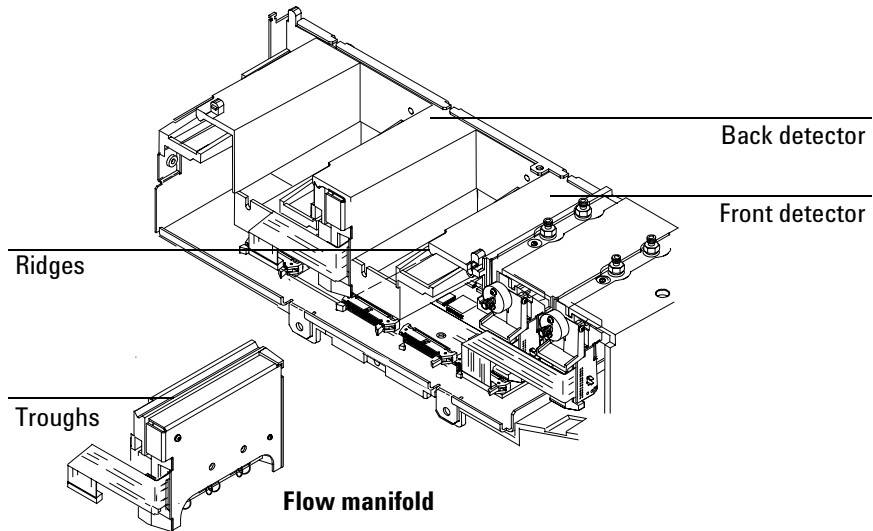

4. Plug the ribbon cable into the front or back connector. Make certain the connector is firmly seated and locked. If the flow manifold is installed and plugged into the correct position, the ribbon cable will retain its fold as shown in the diagram. If you unplugged an inlet ribbon cable in Step 2, replace it.

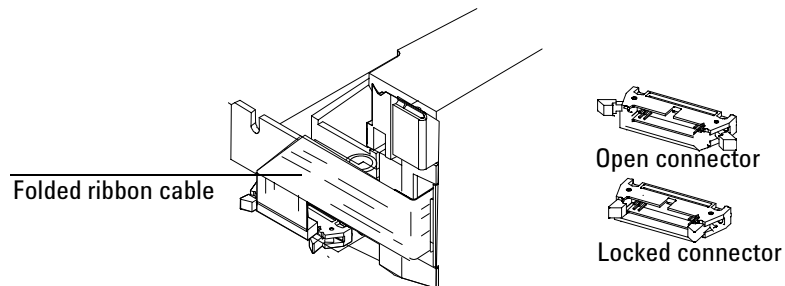

Appendix: Installing the pneumatics module (early version)

5. From the front of the GC, secure the flow manifold to the carrier by tightening the captive screw until snug using a T-20 Torx screwdriver.

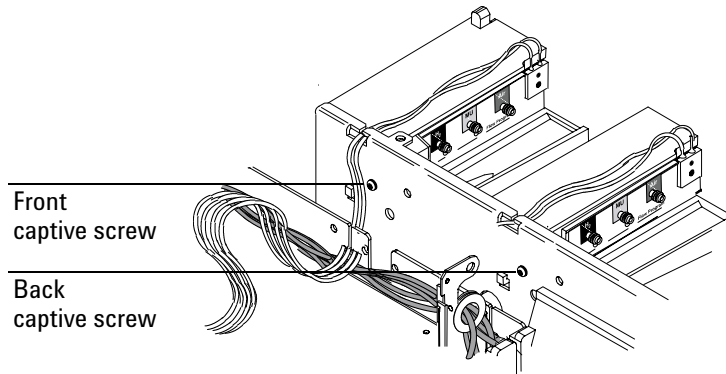

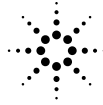

Agilent Technologies



Printed on recycled paper.



This product is recyclable.

Agilent Technologies, Inc.

Printed in USA AUG 2001



G1531-90327